

**TCM**



**Reach Type Stand-up Model**

**FRB-9**

**1.0-3.0 ton**

# FRB-9

Reach Type  
Stand-up Model



TCM yellow color available as an option.

State of the Art  
"Second To None"

FRB-9 boasts the ease-of-use and safety features that enable the operator to concentrate on the work at hand. The result is increased work efficiency.

## Comfort & Safety

Simply by grasping the grip and setting foot on the lowered step, you'll realize just how user-friendly FRB-9 has become. What's more, the operator compartment of FRB-9 has been exhaustively designed to increase the operator's work efficiency. The excellent forward visibility remains, while the operator can enjoy enhanced support resulting from a thorough rethink of the steering wheel angle and the arrangement of the operating levers.



### Pedal with a presence switch

The right side of the driver's platform incorporates an independent pedal with a presence switch. This ensures you can operate while maintaining a safe and stable posture, as this innovation prevents the right heel from protruding from the compartment. In addition, reducing the step height to 265 mm\* contributes to easier operator entry while maintaining conventionally sized caster wheels. \*1.0t and 1.5t models



### Glove compartment and flat top panel for documents

Equipped with a glove compartment and a flat top panel that accepts magnets for simplified document storage.

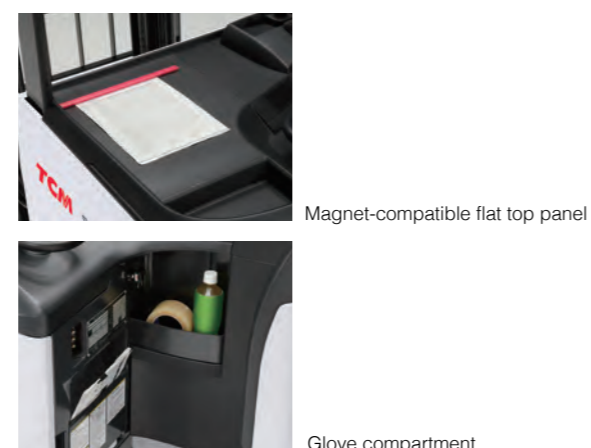

### Soft Landing System

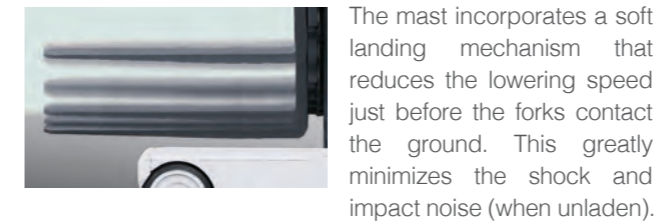

### Load handling and traveling interlock system

Thanks to the interlock system, the display issues a warning when the operator is out of the compartment or not in the correct position for traveling or hydraulic operations. In addition, all operations will be suspended even if the key switch is turned on while any lever is activated.

### Rigid frame for greater durability

The monocoque frame has been introduced to increase durability and enhance strength with a cast iron rear bumper which also ensures ample impact resistance.

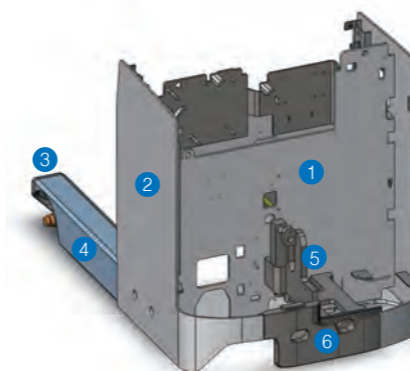

- 1 Main plate
- 2 Side frame
- 3 Cast steel cover for load wheel
- 4 Straddle leg
- 5 Reinforced link support
- 6 Cast iron rear bumper

### Operator friendly steering wheel and levers

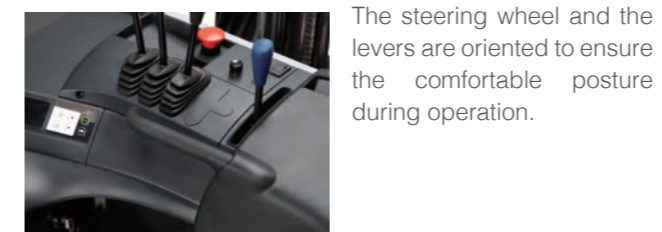

### Operator friendly steering wheel and levers

The steering wheel and the levers are oriented to ensure the comfortable posture during operation.

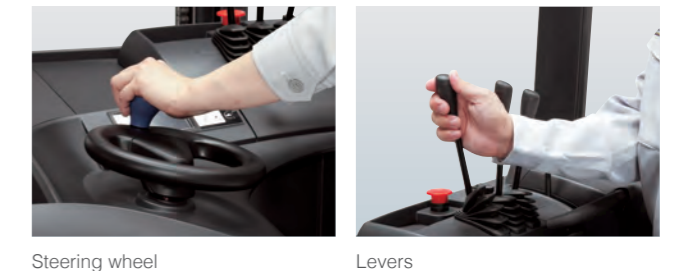

### Large waist pad for reduced operator fatigue



### Antiroll back system

After temporarily stopping on an incline and releasing the brake, you will descend only at very slow speed until you apply the accelerator and easily continue on your way.



Maintains speed of about 1 km/h if you release the brakes with the accelerator off ("Anti-rollback" feature).



Maintains a constant safe speed (by suppressing acceleration on slope descent). (Travel backward when laden.)

Note: Deadman-type brakes are applied when the pedal is released.

# The eco-friendly performance of FRB-9 Series has evolved.

## Eco & Advanced

This vehicle features innovations such as the Eco Switch and customizable operation feeling. Simply switch the mode to vary between powerful operation and eco mode. Thanks to this ability to accommodate varying work environments, FRB-9 Series offers expanded potential.

### The Eco Switch contributes to increased energy-efficiency

In addition to P (Powerful), N (Normal) and C (Customize) modes, FRB-9 Series features Eco Setting. In Eco Mode, daily electricity consumption is cut by 15% by controlling maximum performance such as travel speed and lift speed. Use the Eco Switch to reduce your ongoing electricity consumption when maximum performance is not required.

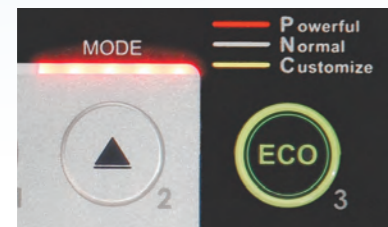

Eco Switch

### Understand vehicle status at a glance

All information is displayed for easy understanding: remaining battery power, travel speed, hour meter, turtle mode icon. This allows for easy management of vehicle status. Moreover, the display can be inverted to match personal preferences or the work environment.



Negative display (Normal)



Positive display (Inverted)

### Easy-to-read display

The transmissive LCD exhibits clear contrast that makes it easier to read and less likely to be affected by sunlight when used outdoors. What's more, the text is larger and the full dot display makes the on-screen information more legible.



### Easily switch from the standard modes to Eco Mode

Depending on the work environment, the operator can directly switch to Eco Mode from any of the three operation modes: P (Powerful), N (Normal) and C (Customize).

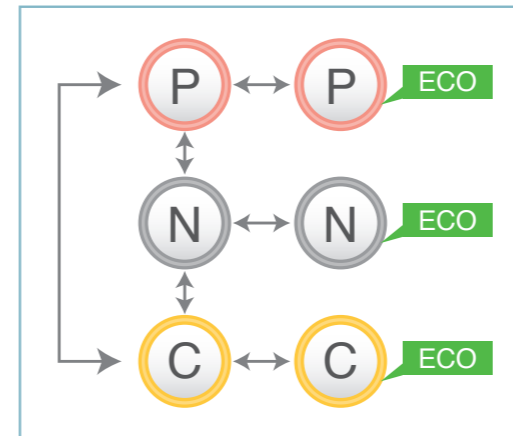

### Auto power-off system

This system automatically conducts to shut off the main power to save the battery power when the truck is not operated more than 15 minutes even if the main key switch is "ON". The hour recording meter of operation also halts to automatically record the actual operation time for management supervision on the truck operation.

15min  
POWER OFF



### Operation characteristics customizing system

It provides flexibility in setting the operation characteristics to match the operator's skill

Through adjustments to the acceleration force, response, and accelerator lever characteristics, the vehicle's response to travel and hydraulic inputs can be adjusted in many ways to accommodate specific usage requirements and the operator's skill. Because adjustments are made through the management screen, the user or service technician can quickly adjust vehicle response settings.



#### Acceleration force

Travel : 16 levels  
Lift / Reach : 9 levels

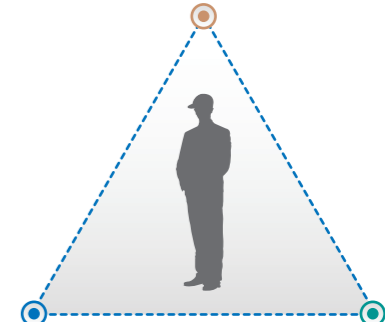

#### Accelerator lever characteristics

Travel : 16 levels

#### Response

Travel : 16 levels  
Lift / Reach : 9 levels

#### Acceleration force

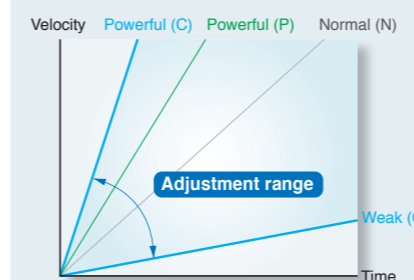

#### Response

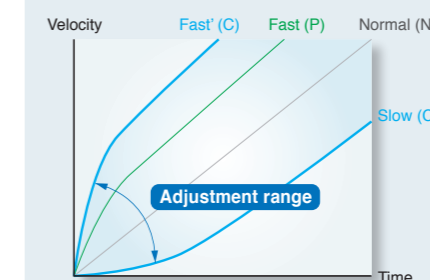

#### Accelerator lever characteristics

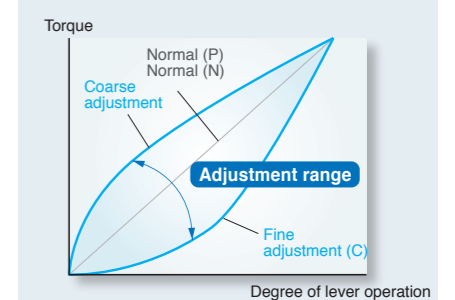

Outstanding stability and traveling performance contribute to reliable operation.

## Performance

From the moment you set it in motion, you'll experience the superior vehicle stability reflecting the further evolution of our advanced control linkage. The rear tires provide grip that is exceptional on uneven road surfaces while providing a consistently comfortable ride. This innovative model incorporates the latest technology for smooth and stable operation — whether accelerating, turning or stopping.

## Central Management System

Two CPUs process the traveling system and hydraulic system independently. Another main CPU manages all other information. The main CPU is connected to the display and handles all operation settings, function settings and indicator settings. The result is comfortable, stress-free operation in a variety of environments.

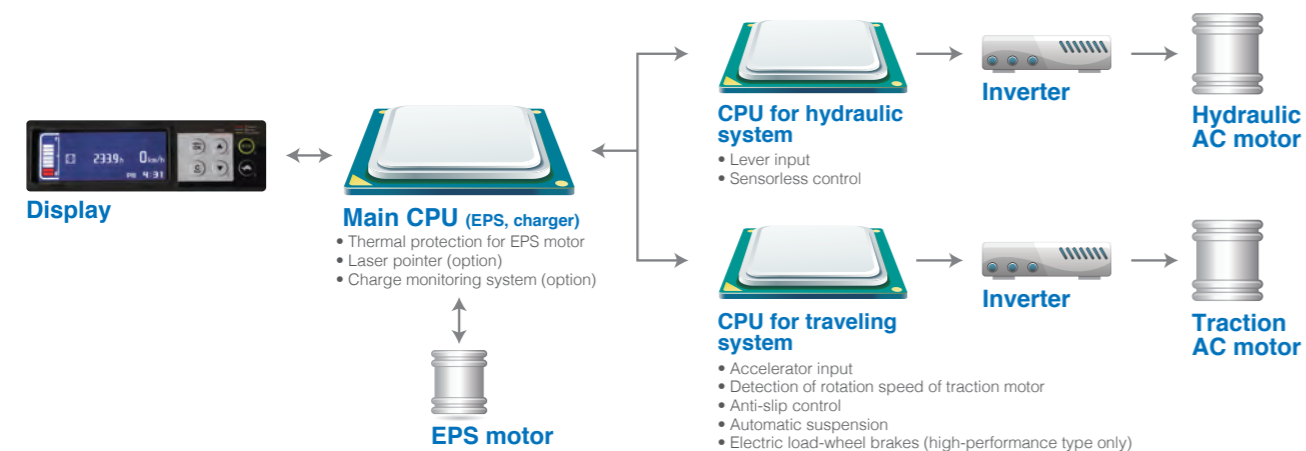

## Improved vehicle stability in turns and hydraulic operations

Sensors detect the status of the travel and hydraulic operation. Depending on the situation, the automatic suspension can lock the control linkage, thus stabilizing the vehicle in turns and hydraulic operations.

- In turns: Reduces compression of the rear wheel suspension and lifting of the load wheel, thus reducing tilting of the vehicle.
- In hydraulic operations: Reduces vehicle tilting to the left and right and forward tilting as a result of lift or reach operations.

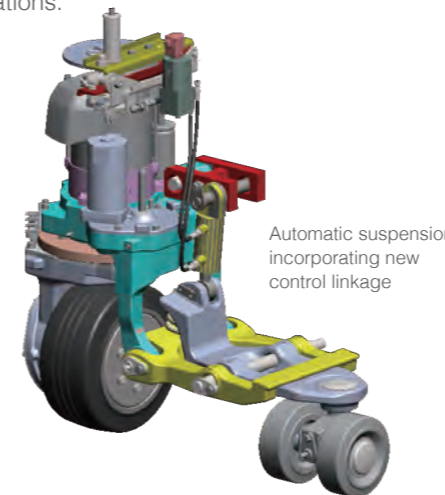

## New control linkage

The automatic suspension enhances safety in tight turns and during rapid acceleration and braking, locking the caster wheel according to the vehicle status.



## Anti-slipping control

This feature automatically limits power when tire slippage is detected during travel. It ensures the optimal driving force is consistently applied to maintain smooth operation.

- Comparison of starts on a wet surface

### Without anti-slipping control



### With anti-slipping control

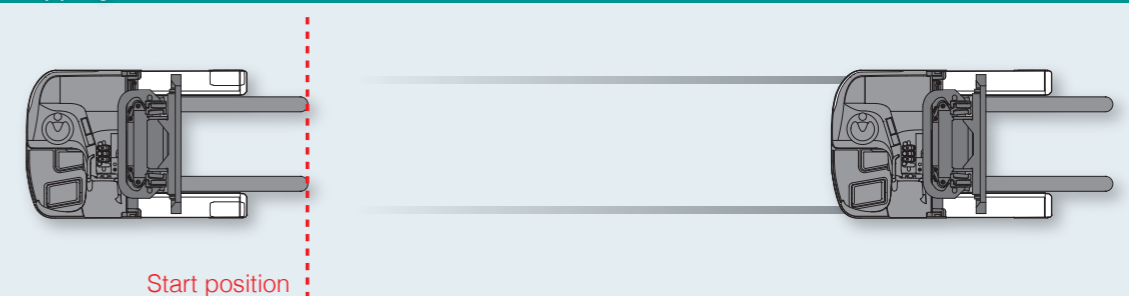

## Standard 1-ton model

48 V, 1090-mm width

### Standard mast type

**3-m**  
mast

1.2t



### High mast type

**4-m**  
mast

1.2t

Long wheelbase



## Standard 1.5-ton/2-ton/3-ton models

### Standard mast type

**3-m**  
mast

1.5t  
1.8t  
2.0t  
2.5t  
3.0t



### High mast type

**4-m**  
mast

1.5t  
1.8t  
2.0t  
2.5t  
3.0t

Long wheelbase



## Narrow chassis series

24 V, 990-mm width. Ideal for facilities with limited space.

### Standard mast type

**3-m**  
mast

1.0t  
1.2t



## Option

### Laser Beam Positioning Unit

The red color laser beam clearly indicates the position of fork pockets of the pallet, allowing even untrained operators easily conduct pallet handling operations.

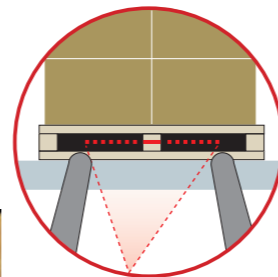

### Password Entry System

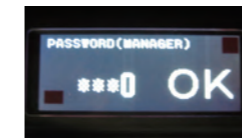

For security to prevent misuses of trucks by unauthorized operators, FRB-9 Series is equipped with this new system, whereby operators have to input their individual code numbers to release the lock before start up the truck.

### Load Meter

The multi-display instantly shows the weight of the load. This convenient function makes it easy to avoid overloading and underloading. The tare weight setting easily allows the operator to deduct the weight of packaging and pallets. (This function is NOT for commercial use.)

### Semi-Cold-storage Specification

Capable of indoor/outdoor operation in refrigerator-freezer temperatures of -35°C.



### Fully Cold-storage Specification

Capable of long hours of operation in refrigerator-freezer temperatures of -35°C, as well as indoor/outdoor operation at -55°C.





**TCM**

<http://www.tcm-forklift.jp>

© 2018 by ML. All rights reserved. Printed in Japan.

**Note:**

These products and specifications are subject to change without notice.  
Photos and illustrations may slightly differ from the actual trucks.  
Photos and illustrations may or may not include optional equipment and accessories.  
Features and specifications may vary depending on markets.  
Performance data and dimensions are nominal and subject to tolerances.  
Produced in ISO certified factory.

PRESENTED BY :