



UD TRUCKS

# Quester

GWE64T11MS



Going the Extra Mile

# GWE64T11MS Specifications

## PERFORMANCE

Minimum Turning Radius: 7,450mm

1. Maximum Speed and Gradeability @ 60,000kg

2. Maximum Speed and Gradeability @ 70,000kg

3. & 4. Maximum Speed and Gradeability @ 80,000kg

No.	Max. speed km/h	Gradeability (tan θ)%	Transmission	Final ratio	Rear axle type
1	105	26.10%	STO2012	4.63	Single reduction

## ENGINE

Make and model	UD Trucks GH11 390 EC01 Diesel Engine
Euro Emission	EURO 3
Type	4 cycles, direct injection, water cooled, in-line diesel engine, turbocharged with intercooler
Number of cylinders	6
Bore x Stroke	123 mm X 152 mm
Total piston displacement	10,837 cc
Max. output	390 HP (293 kW) @ 1,900 rpm
Max. torque	187 kg.m (1,836N.m) @ 1,000 - 1,400 rpm
Fuel system	Electronic Management System (EMS) fuel injection system
Air cleaner	Dry paper with dual filter
Fuel tank capacity	405 litres

## CHASSIS

Clutch	Dry single plate, hydraulically operated clutch release mechanism with air assisted booster
Front axle	Drop forged steel "I" section beam reverse "Elliot" type
Rear axle	Full - floating drive axle in line tandem type
- Single reduction	Single reduction, hypoid gear
- Hub reduction	Differential lock between axles (Interaxle) Hub reduction, hypoid gear
Steering	Differential lock between axles and between all wheels Re-circulating ball screw type, hydraulic power assist, adjustable tilt / telescopic
Service brake (foot brake)	Full air brakes actuated on all wheels, S-cam type with automatic slack adjuster, Anti-lock Braking system (ABS)
Parking brake (hand brake)	Pneumatically controlled spring brake operated by gradual type control valve, acting on all wheels
Emergency brake	Spring brake acting on front and rear axles
Auxiliary brake	UD Extra Engine Brake including Exhaust pressure governor
Front suspension	Parabolic leaf springs with anchor at front and shackle at rear, telescopic type shock absorber
Rear suspension	Multi-leaf springs with stabilizer

## TRANSMISSION

Model	STO2012
Type	12 forward speeds and 2 reverse, synchromesh on 2nd to 12th gear, constant mesh on 1st and reverse gear
Gear shift	Mechanical remote control

## WHEELS & TYRES

Tyres	295/80R 22.5 16PR
Rim	Pressed steel disc type, 9.00 x 22.5 ISO 10 studs
Spare wheel	One spare wheel / tyre with carrier

## FRAME

Frame	Thermo-mechanically rolled frame, rivet free at top of chassis frame
Main frame dimensions	300 mm x 90 mm x 8 mm
Inner liner dimensions	277 mm x 80 mm x 5 mm

## ELECTRICAL EQUIPMENT

Battery	150 A.h. 12 Volt x 2
Alternator	24-volts 80 ampere
Headlights	Halogen headlight, headlight level control switch
Others	Tail lights, stop light, license light, side clearance light, turn signal light, back-up light, trailer working light, horn

## CABIN

Type	Sleeper cab (UN ECE R29 compliant), Forward control with manual hydraulic cab tilting, coil spring with shock absorber.
Instrument panel	Speedometer with odometer and trip meter
- Meters	Tachometer Fuel gauge Engine coolant temperature gauge Air pressure gauge
- Warning lights and buzzers	Low engine oil pressure indicator Head light high beam indicator Turn signal indicator lights Battery charge warning indicator Hazard warning flasher (4-way) Parking brake warning light Air cleaner dog warning indicator

## STANDARD FITMENTS

Fuel coaching system	✓
Exhaust brake	✓
UD Extra Engine Brake	✓
Power window	✓
Sun visors (for driver and co-driver)	✓
Under mirror	✓
Air dryer	✓
Exterior mirrors with electric heater	✓
Driver seat air suspension (auto weight adjustment)	✓
Auxiliary passenger seat	✓
UD Standard tools (1 set)	✓
Bottle Jack (20 ton)	✓
Wheel chocks (2 pieces)	✓
5th wheel, trailer connectors	✓
Transmission PTO	Optional

## WEIGHT (kg)

Chassis with cab (Approx - Include crew)	8,871
- On front axle	5,176
- On rear axles	3,695
Permissible gross vehicle weight	34,000
Permissible front axle load	8,000
Permissible rear axle load	26,000
Permissible gross combination weight	60,000 - 80,000

## DIMENSION (mm)

Wheelbase (WB)	3,400	Rear tread (RT)	1,836
Overall length (OL)	7,301	Front overhang (FOH)	1,460
Overall width (OW)	2,500	Rear overhang (ROH)	805
Overall height (OH)	3,285	Ground clearance (GC)	261 (Opt1 & 2)
Front tread (FT)	2,020		302 (Opt3 & 4)

NOTE: As product improvements may be introduced at any time, specifications are subject to change without notice.

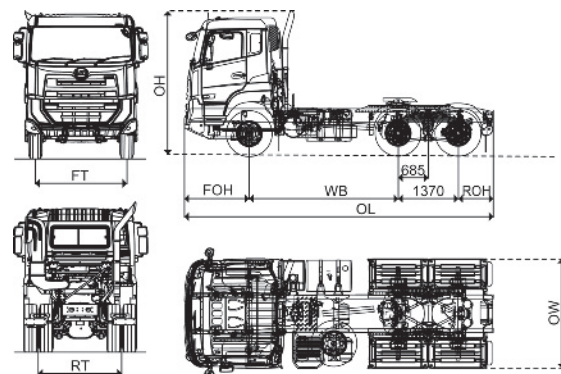

Plot 43, Lambak Kanan Industrial Area (West),  
Jalan Pasir Berakas, BB1714, Brunei Darussalam  
Tel: 239 3658 Fax: 239 3659  
Email: cvsales@bousteadcars.com