



Volvo Trucks. Driving Progress

VOLVO FM

FM 370 4X2T RSS I-SHIFT

PRIME MOVER



GVW : 21,500Kg
GCW : 60,000Kg
FRONT AXLE LOAD : 8,500Kg
REAR AXLE LOAD : 13,000Kg

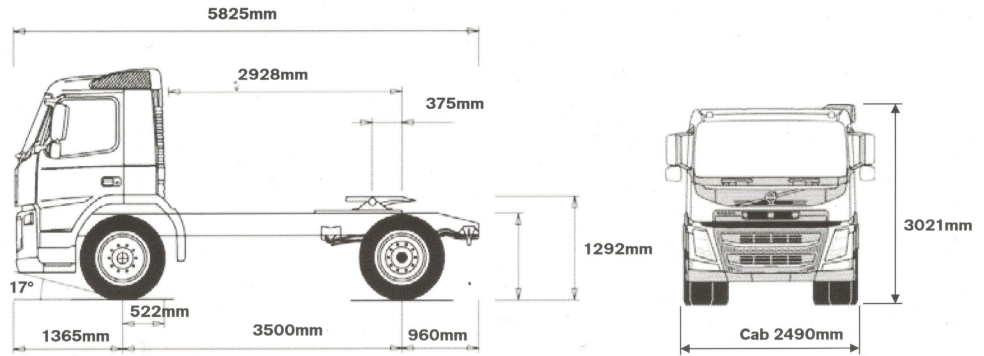

ENGINE

D11A370 - Diesel engine, 11-litres (Euro 3)
 In-line six cylinders inter-cooled turbo charged
 Engine Management System (EMS) with Cruise Control and Speed Limiter
 Incorporated with Volvo Engine Brake, VEB (compression brake with Exhaust Pressure Governor, EPG)
 Bore X Stroke 123mm X 152mm
 Maximum output: 370hp
 Maximum torque: 1770Nm
 Economy engine speed range 1050-1500 rpm

GEARBOX

AT2612D
 I-Shift automated mechanical 12-speed gearbox without clutch pedal, maximum engine torque 2,600Nm, maximum permitted GCW 60,000kg

REAR AXLE

RSS1360, rear single reduction solo axle
 Maximum axle load: 13 tonnes

FRONT SUSPENSION

2-leaf front parabolic suspension (normal stiffness)
 Front stabilizer (medium high stiffness)

REAR SUSPENSION

Rear progressive parabolic leaf suspension
 Rear stabilizer (normal stiffness)

BRAKE SYSTEM

Drum brakes
 ABS - Anti-lock braking system
 Two (2) extra parking brake chambers
 Front axle regulating brake valve with reduced pressure / low pressure range

EXHAUST SYSTEM

Horizontal muffler, right exhaust outlet

DIMENSION/WEIGHT

Front Thread 2,028mm
 Rear Thread 1,837mm
 Curb Weight 6,609Kg

RIM SIZE

22.5 x 9.0J, Pressed Steel Rim

TYRE SIZE

315/80R22.5, tubeless tyre

ELECTRICAL EQUIPMENT

Batteries 170Ah - two (2) pcs
 Battery voltage and ampere gauge
 Chassis main switch - battery box placed toggle switch circuit shut down

FUEL TANK

330 litres aluminium 710mm high D-shaped diesel tank
 Fitted with lockable diesel caps
 Fuel filling anti-spillage device

POWERTRAIN

Basic performance cooler for I-Shift gearboxes - water / oil
 Dual cylinder air compressor 704cc / 1080 l/min
 High air intake
 Air cleaner with one filter element
 Alternator 110 ampere
 Open crankcase ventilation
 Manual priming pump
 Large engine mounted dual fuel filter with water separator and drain

CABIN

FM-SLP sleeper cabin
 Electrical manually controlled air-conditioning system
 Dashboard integrated 4" color information display
 Mechanically adjustable steering wheel
 Cruise control (control in steering wheel)
 Road Speed Limiter Setting
 Internal sun-visor (driver side only)
 Electrical window lift
 Back-up alarm

LIGHTING

Halogen H7 head lamps
 V shape (V-light) day running light (LED)
 LED tail lamps
 Brake light
 Cornering lights
 White front fog lamps
 Rear marker lights and side reflectors
 Two (2) rear roof mounted amber warning lamps

ACCESSORIES

Air horn (Jericho type)
 Air-conditioning system
 Audio basic
 Rubber floor mats
 Telematics Gateway (Preparation kit)

ANCILLARY EQUIPMENT

Mud flaps with anti-spray (front axle fenders)
 Rear three (3) pieces fenders with anti-spray function (rear axles)

FOR TRAILER CONNECTION

Jost JSK 37 cast iron fixed fifth wheel
 Fifth wheel ISO mounting on medium L-profiles
 Trailer brake connection, European Community
 Stationary trailer brake control
 Trailer arch working lamp with white lens and LED bulb

BOUSTEAD SDN BHD

BSB

Lot No. 24 & 29, Beribi Industrial Complex II,
 Jalan Gadong BE1118, Brunei Darussalam
 Tel: +6732431333 Fax + 673 242 0459

KB Branch

Lot 8989, Units 1-4 Block A, Jalan Pandan 7,
 Kg Pandan KA1931, Kuala Belait Brunei Darussalam
 Tel + 673 333 4284 Fax +673 333 4286

Service & Parts Centre

Plot 43, Lambak Kanan Industrial Area (West),
 Jalan Pasir Berakas BB1714, Negara Brunei Darussalam
 Tel + 673 239 3713 Fax +673 239 3659